

A.S. MACHINES & SERVICE

24 YOM HA'KIPURIM ST. HOLON 58485 ISRAEL

TL: +972-505256468 FAX : +972-3-5566824

www.a-saranga.com saranga.avi@gmail.com



א.ס. שרותי הנדסה

רח' יום הכיפורים 24 חולון 5848567

טל. 03-5566824 פקס. 050-5256468

אבי סרנגה נייד 050-5256468



S E R I E

F-R

Fustellatrice a Braccio Rotante Motorizzato
Clicking Press with Motorised Rotating Arm
Presse a Decouper avec Bras Tournant Automatisé
Cortadora a Troquel con Brazo Giratorio Motorizado



Avvio pompa e pulsante emergenza
Pump starter and emergency button



Touch Screen



CLICKING PRESS WITH MOTORISED ROTATING ARM

The new series of F-R punching machines with motorised rotary arm is available both in EC as well as not EC versions at truly competitive prices, with the advantage of less taxing usage for operator, and consequential positive effects for company production.

The version for countries subjected to EU standards is supplied with a series of external protection devices, photo electrical protection barriers and an electrical system including various safety devices and lateral tables. For the not EC version, external protection devices with or without photo electrical barriers are supplied upon request, in this case two practical lateral tables are supplied.

Light bulb and stroke counter (additional or programmable type) are available upon request for both version.

FUSTELLATRICI A BRACCIO ROTANTE MOTORIZZATO

La nuova serie di fustellatrici F-R con braccio rotante motorizzato è disponibile sia in versione CE che Extra CE ad un prezzo sicuramente competitivo, con il vantaggio di un utilizzo meno affaticante per l'operatore, e conseguente riflesso positivo sulla produzione aziendale. La versione per paesi soggetti a normative CE è fornita di serie di protezioni esterne, barre fotoelettriche di protezione e impianto con dispositivi vari di sicurezza e tavolini laterali. Per la versione Extra CE le protezioni esterne con o senza barriere fotoelettriche sono fornibili a richiesta, in questo caso vengono anche forniti due comodi tavolini laterali.

Lampada e conta colpi (addizionale o programmabile) sono a richiesta per entrambe le versioni.

PU VERSION



Pulsantiera di controllo Control panel with pushbuttons

TA VERSION



Tasti regolabili

Adjusting keyboard

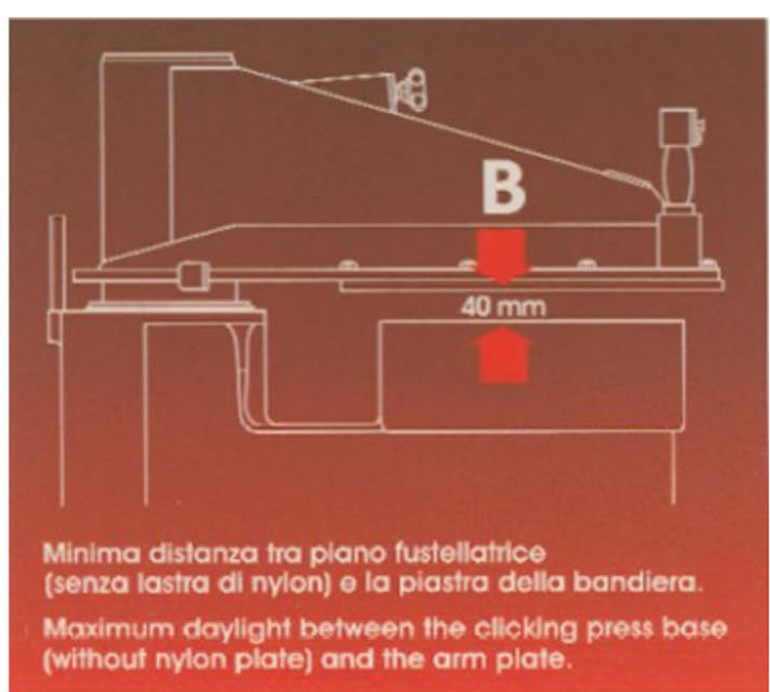
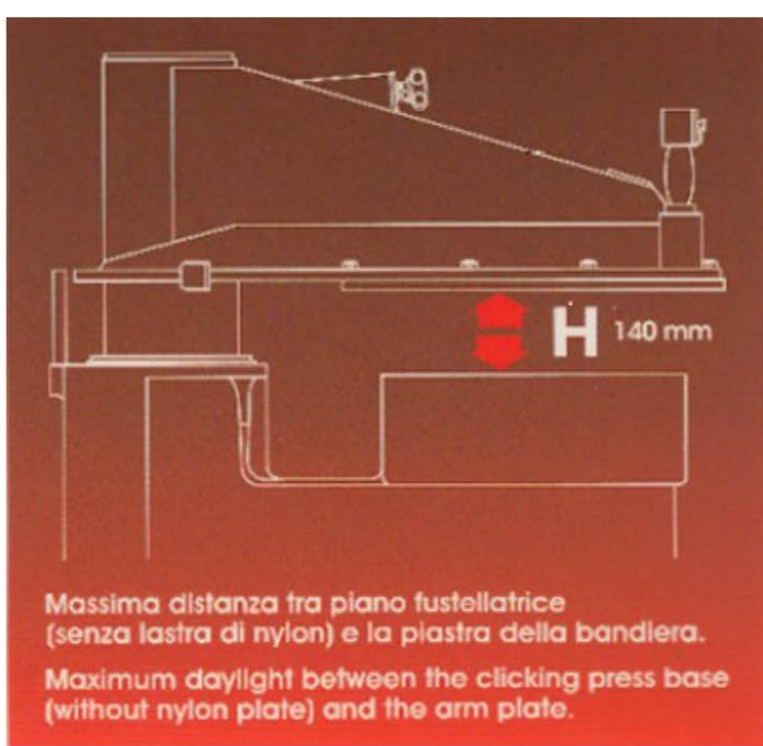

ACCESSORI

Ceppo da 50mm,
 Contacolpi a 4 cifre addizionale,
 Contacolpi a 6 cifre (preselezione),
 Resa F.O.B.

ACCESSORIES

50mm nylon pad,
 Stroke counter 4-digit (adder),
 Stroke counter 6-digit (preset),
 Dispatch F.O.B.

ACCESSOIRES

Souche à 50 mm en nylon
 Compteur de cycles à 4 chiffres (additionneur),
 Compteur de cycles à 6 chiffres (préréglée),
 Envoi F.O.B.

ACCESORIOS

Bloque de nylon 50mm,
 Contador de golpes de 4 dígitos (víbora),
 Contador de golpes de 6 dígitos (preestablecido),
 Despacho F.O.B.

DATI TECNICI - TECHNICAL DATA - DONNES TECHNIQUES - DATOS TECNICOS	F50 R	F56 R	F60 R	F65 R	F70 R
Potenza massima - Maximum power - Puissance maximale - Potencia màxima [Ton]	27	27	27	27	27
Corsa massima - Maximum stroke - Course maximale - carrera màxima [mm]	100	100	100	100	100
Piano di Lavoro - Working table - Plan de travail - Plano de trabajo [mm]	900 x 450	900 x 450	1000 x 500	1000 x 500	1000 x 500
Larghezza braccio - Arm width - Largeur du bras - Longitud brazo [mm]	380	500	500	380	500
Potenza motore pompa - Pump motor power - Puissance moteur pompe - Potencia motor bombo [Cv / kW]	1.5 / 1.1	1.5 / 1.1	1.5 / 1.1	1.5 / 1.1	1.5 / 1.1
Potenza motore rotazione bandiera - Flag rotation motor power [Cv / kW] Puissance moteur rotation porte-planche - Potenciamotor motor montado sobresaliente [Cv / kW]	0.75 / 0.75	0.75 / 0.75	0.55 / 0.75	0.55 / 0.75	0.55 / 0.75
Peso netto con olio (con lampada e protezioni) - Net weight with oil (with light and protections) [Kg] Poids net avec de l'huile (avec lampe et protections) - Peso neto con aceite (con lámpara y protecciones) [Kg]	930	970	990	950	1050
Ingombro macchina montata - Overall dimensions assembled [mm] Dimensions hors assemblés - Dimensiones máximas ensamblados [mm]	1900x1500 H 2100	1900x1500 H 2100	1900x1500 H 2100	1900x1500 H 2100	1900x1500 H 2100
Peso lordo con imballo - Gross weight with packaging [Kg] Poids brut avec emballage - Peso bruto con embalaje [Kg]	1050	1090	1010	1070	1170
Ingombro con imballo - Dimensions with packaging [mm] Dimensions avec emballage - Dimensiones con embalaje [mm]	1050x1150 H 1570	1050x1150 H 1570	1050x1150 H 1570	1050x1150 H 1570	1050x1150 H 1570



A.S. MACHINES & SERVICE

24 YOM HA'KIPURIM ST. HOLON 58485 ISRAEL

TL: +972-505256468 FAX: +972-3-5566824

www.a-saranga.com saranga.avi@gmail.com



א.ס. שרותי הנדסה

רח' יום הכיפורים 24 חולון 5848567

טל. 03-5566824 050-5256468 פקס.

אבי סרנגה נייד 050-5256468